

NO.	PART NAME	MATERIAL
1	BODY	SSTL ASTM A351 GR. CF8M
2	SCREEN	
	PERF. DIA.	
	MESH	
3	B.O. PLUG	SSTL ASTM A351 GR. CF8M
4	GASKET	NON-ASBESTOS

PRESSURE RATING: 1440 PSI @ 100° F
(99 BAR @ 37.8° C)

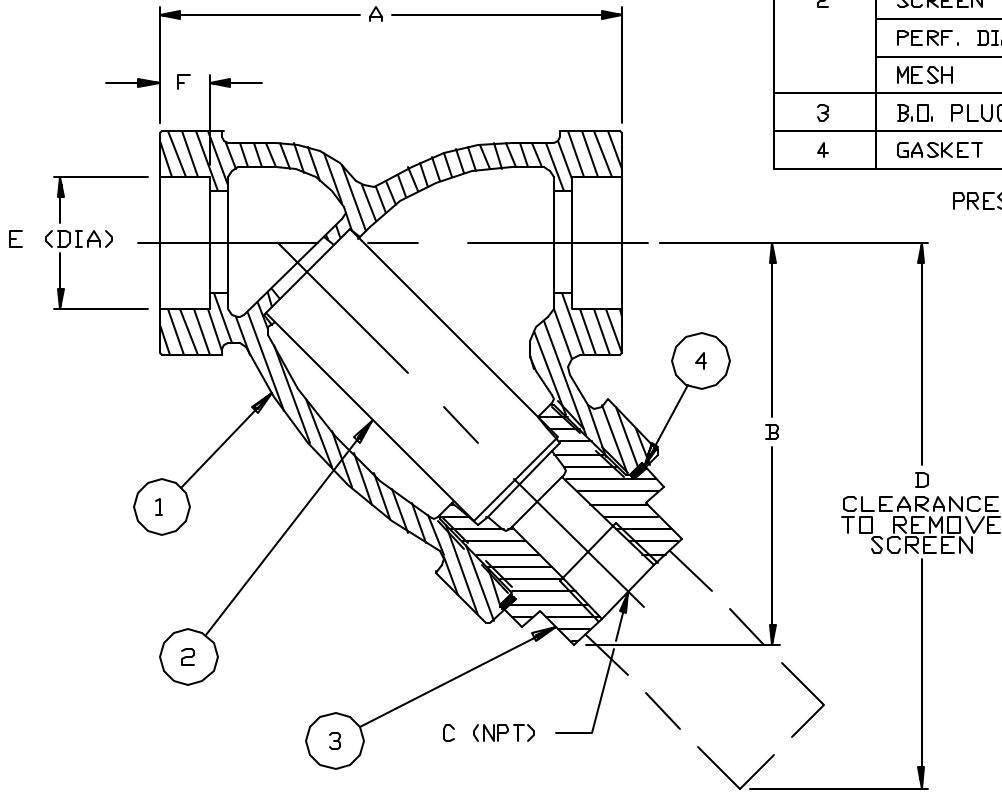

CERTIFIED FOR:
P.O. NO.:
REG. NO.:
TAG NO.:

QUOTE NO.:

PIPE SIZE (NOMINAL)	DIMENSIONS						WEIGHT (APPROX.) (DRY) LBS. KGS.	HAYWARD PART NO.							
	A		B		C (NOM)				D		E		F		
	IN.	MM.	IN.	MM.	IN.	MM.	IN.	MM.	IN.	MM.	IN.	MM.			
1/4" (8mm)	3.00	76	3.00	76	3/8	<10>	4.00	102	0.56	14	0.38	10	2	0.9	SY085002ES20A
3/8" (10mm)	3.00	76	3.00	76	3/8	<10>	4.00	102	0.69	18	0.38	10	2	0.9	SY085003ES20A
1/2" (15mm)	3.00	76	3.00	76	3/8	<10>	4.00	102	0.86	22	0.38	10	2	0.9	SY085005ES20A
3/4" (20mm)	3.75	95	3.50	89	3/8	<10>	4.75	121	1.07	27	0.50	13	4	1.8	SY085007ES20A
1" (25mm)	4.63	118	4.00	102	1/2	<15>	5.75	146	1.33	34	0.50	13	6	2.7	SY085010ES20A
1-1/4" (32mm)	5.00	127	4.63	118	3/4	<20>	6.50	165	1.68	43	0.50	13	8	3.6	SY085012ES20A
1-1/2" (40mm)	5.63	143	5.25	133	3/4	<20>	7.50	191	1.92	49	0.50	13	10	4.5	SY085015ES20A
2" (50mm)	7.00	178	5.75	146	1	<25>	8.75	222	2.41	61	0.62	16	15	6.8	SY085020ES20A



HAYWARD INDUSTRIAL PRODUCTS, INC.

900 FAIRMOUNT AVENUE, ELIZABETH, NEW JERSEY 07207

NAME: **MODEL 85 Y-STRAINER**
CLASS 600 SOCKETWELD CONNECTIONS
SIZES 1/4" THRU 2" STAINLESS STEEL

UNAUTHORIZED USE, MANUFACTURE OR REPRODUCTION IN WHOLE OR IN PART IS PROHIBITED. DRAWING, DESIGN AND OTHER DISCLOSURES PROPERTY OF HAYWARD INDUSTRIAL PRODUCTS, INC.

DRAWN	FC	DATE	7/6/93	CERT.	FM	DATE	7/6/93
SIZE	DWG	SD085172				REV	C
A	NO						

ELECTRONIC FILE NAME: SD085172.DWG

REF. ECR 3366 DATE 1/25/95