

NO.	DESCRIPTION	MATERIAL
1	FLANGED Y	BRONZE
2	BUTTERFLY VALVE	BODY: IRON SEAL: BUNA-N DISC: ALUM-BRONZE
3	BODY	BRONZE
4	LINKAGE	STEEL
5	COVER	BRONZE
6	SWING BOLTS	CARBON STEEL
7	GEAR OPERATOR	IRON
8	BASKET	
	PERF. DIA.	
	MESH SIZE	
9	O-RING	BUNA-N
10	BOLT/NUT	CARBON STEEL
11	PIPE PLUG (DRAIN)	BRONZE
12	PIPE PLUG (VENT)	BRONZE
13	PIPE PLUG (GAGE)	BRONZE

NOTES:

1. INLET/OUTLET FLANGE PER ANSI B16.24 CLASS 150 FF FLANGE.
2. MAX. WORKING PRESS.: 200 PSI @ 100° F. (13.8 BAR @ 37.8 C)
3. DIMENSIONS ARE IN INCHES / (MM).
4. WEIGHT: 3100 LBS. (1406 KG.)

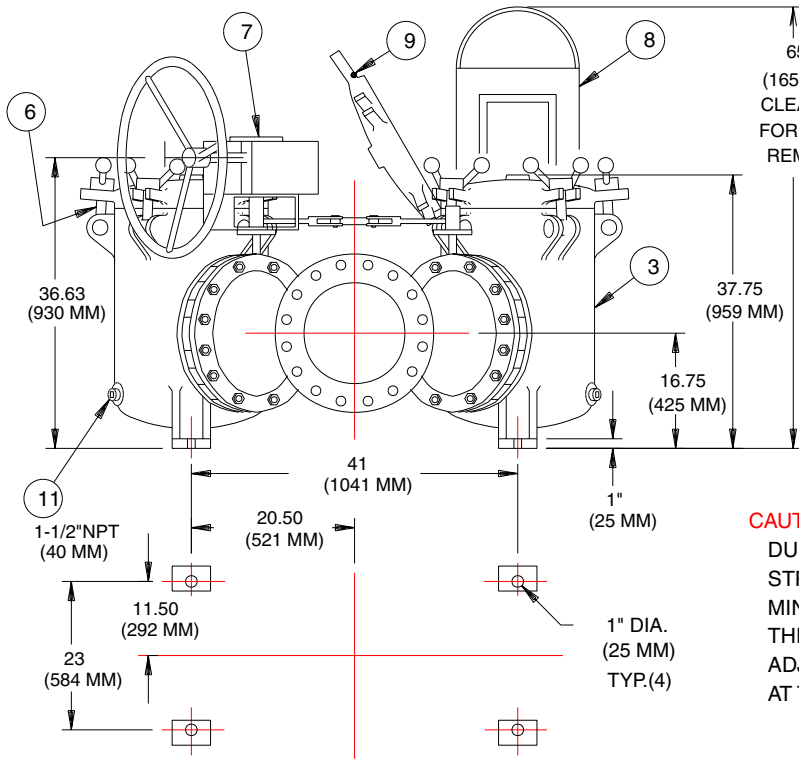

PLAN VIEW
(MOUNTING)

CUSTOMER:
P.O. NO.:
REG. NO.:
QUOTE NO.:
TAG NO.:

CAUTION:

DUE TO THE TYPE OF CONSTRUCTION OF THIS STRAINER, ALL DIMENSIONS MAY VARY PLUS OR MINUS 1.50% OF THE CHARTED FIGURES. THE CUSTOMER IS ADVISED NOT TO FABRICATE ADJOINING PIPING UNTIL RECEIPT OF THE UNIT AT THE JOB SITE.

ELECTRONIC FILE NAME: SD052105.DWG

REF ECR 3366 DATE 1/25/95

UNAUTHORIZED USE, MANUFACTURE OR REPRODUCTION IN WHOLE OR IN PART IS PROHIBITED. DRAWING, DESIGN AND OTHER DISCLOSURES PROPERTY OF HAYWARD INDUSTRIAL PRODUCTS, INC.



HAYWARD INDUSTRIAL PRODUCTS, INC.
900 FAIRMOUNT AVENUE, ELIZABETH, NEW JERSEY 07207

NAME MODEL 50 DUPLEX STRAINER
150# FLAT FACE FLANGE
SIZE 12" BRONZE

DRAWN FM DATE 3/14/94 CERT. GJL DATE 3/14/94

SIZE DWG NO A REV D SD052105